



BAUER

FOR A GREEN WORLD



Submersible Motor Mixer

Optimal Solution for Slurry Mixing

Submersible Motor Mixer

Optimal mixing of liquids in agriculture, biogas plants, waste-water treatment plants and industry.

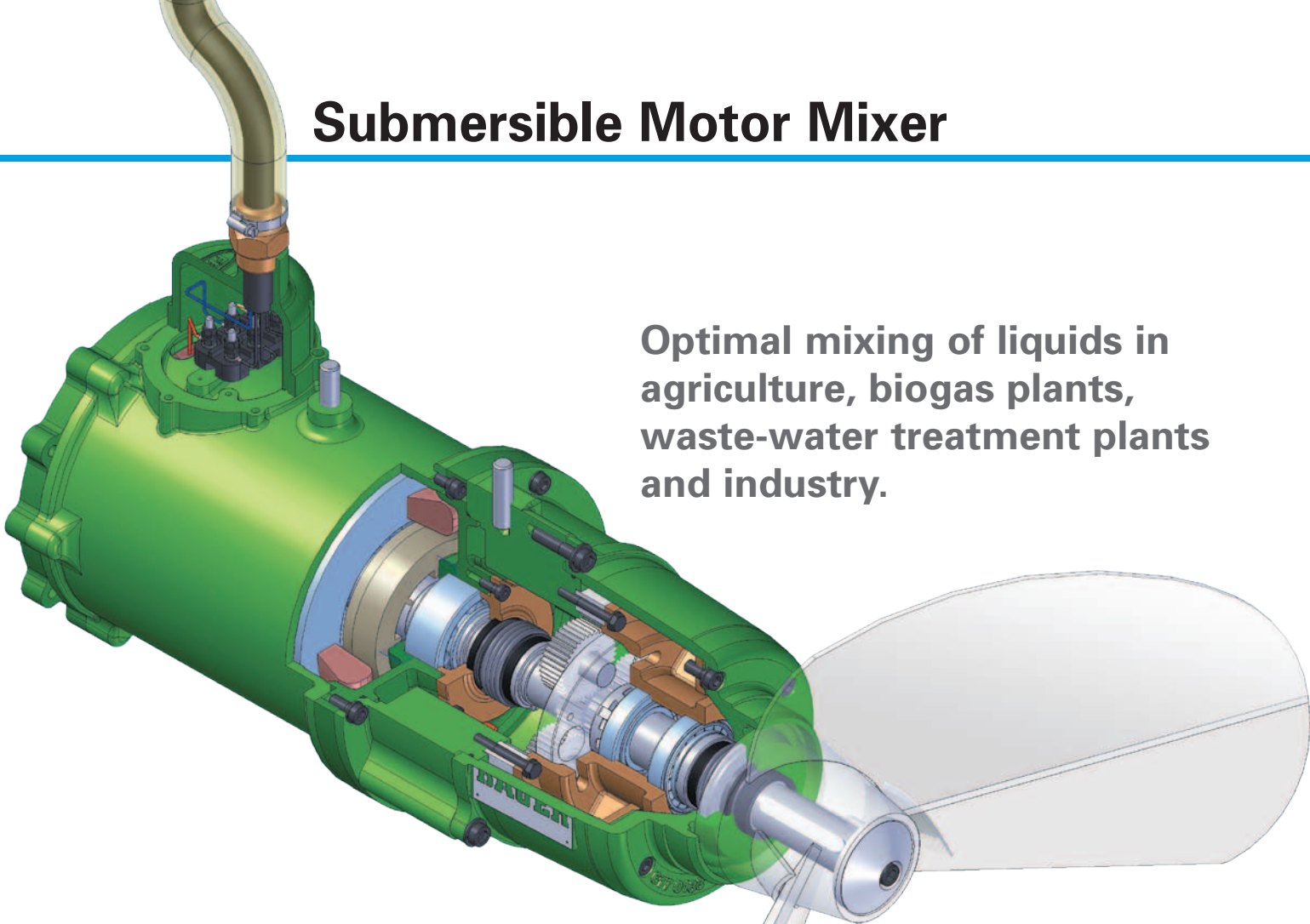

Three phase submersible motor

For optimal protection a thermic winding protection is installed in the motor. The thermic winding protection (PTC-resistor) has a phase protection device and is over voltage and low voltage proof as well as capacity overload proof.

Medium temperature MSX up to 104 °F.

Strong planetary reduction gear unit that guarantees high efficiency

High stability due to various hardened and polished interlocking gears. These gears reduce the friction, which results in less power consumption and high efficiency.

Efficient design – high quality material

A special design concept, achieved by aligning the motor and propeller on the same axle level, guarantees high efficiency. The resulting elegant and streamlined motor design has an additional effect on the efficiency.

The heavy-duty propeller shaft is equipped with shoulder roller bearings. A cleverly devised oil guiding system guarantees that the mixers are well lubricated in every position.

Special shaft seal

Two high quality mechanical seals guarantee trouble-free operation and a long life span.

Sturdy cable

With strain relief device that guarantees operating safety.

Two-wing thrust propeller

Made of stainless steel, self cleaning; high efficiency due to large diameter and special thrust edge.

Explosion protection device as safety device

For the special application of submersible mixers in biogas plants BAUER has equipped the mixers with level probes that guarantee safety shut off when the mixers come out of the liquid medium in the fermenter.

TÜV proofed corresponding to DIN EN 50020:2003-8.

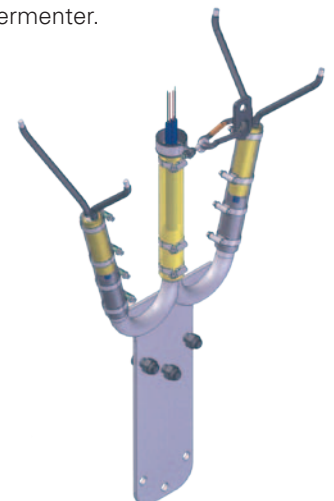
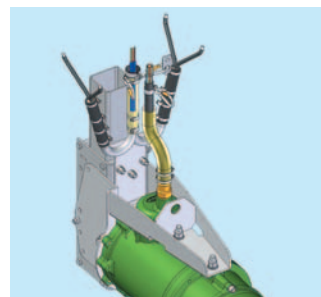



MSX submersible mixers for pits and slalom systems

Lifting-and lowering device for open an closed tanks

- easy installation, handling and maintenance
- stable square guiding pipe 100/100 with swivelling bearing
- winch, 1984 lbs traction force, stainless cable, self locking
- **All parts that get in touch with the medium are in stainless steel.**



Slalom system

- mixing of the slurry in an endless channel via timing device
- well mixed slurry all the time
- distribution possible every time

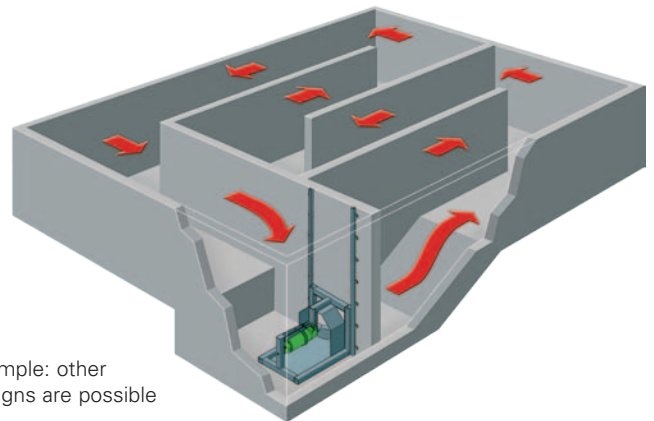

Example: other designs are possible

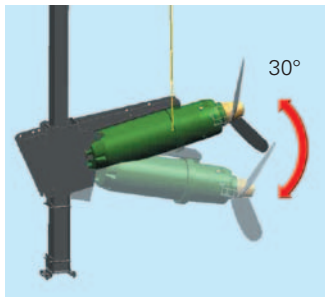

Guiding bracket with an adjustable angle of inclination

guarantees an even better mixing result and a faster dissolving of floating material and bottom sediments.

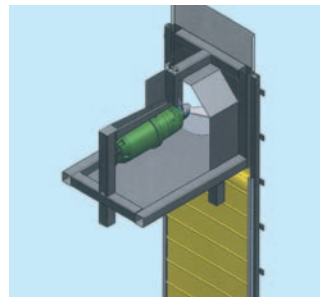

Application in deep slurry pits

Optional: Height adjustable mixing channel with back up canvas plane for optimum mixing results.

Submersible motor mixer MSXH in biogas plants

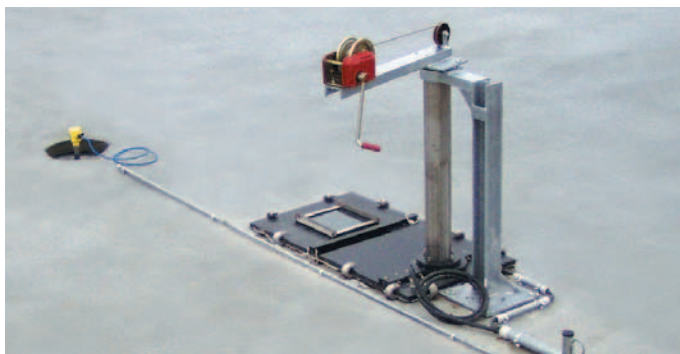

Lifting-and lowering device for fermenter with gas proof service lid

- Gas tight interface for all external parts
- Easy to handle / adjustment of the mixer
- Swivelling and height adjustable from the outside
- Optimum mixing of the fermenting substrates



Gas tight interface in tank wall

with control elements on the outside.



BAUER

FOR A GREEN WORLD

Technical data

MSX	■ MSX 8.5	■ MSX 12.5
Output [HP]	11.7	17.0
Voltage [V]	240 / 480	240 / 480
Frequency [Hz]	60	60
Mixing power* [USgpm]	17 000	25 000
Pit volume* [USgal]	396 000	634 000
Propeller [inch]	21.5	23.5
Propeller [rpm]	378	378
Weight [lbs]	430	450

*) depending on media

Flow range

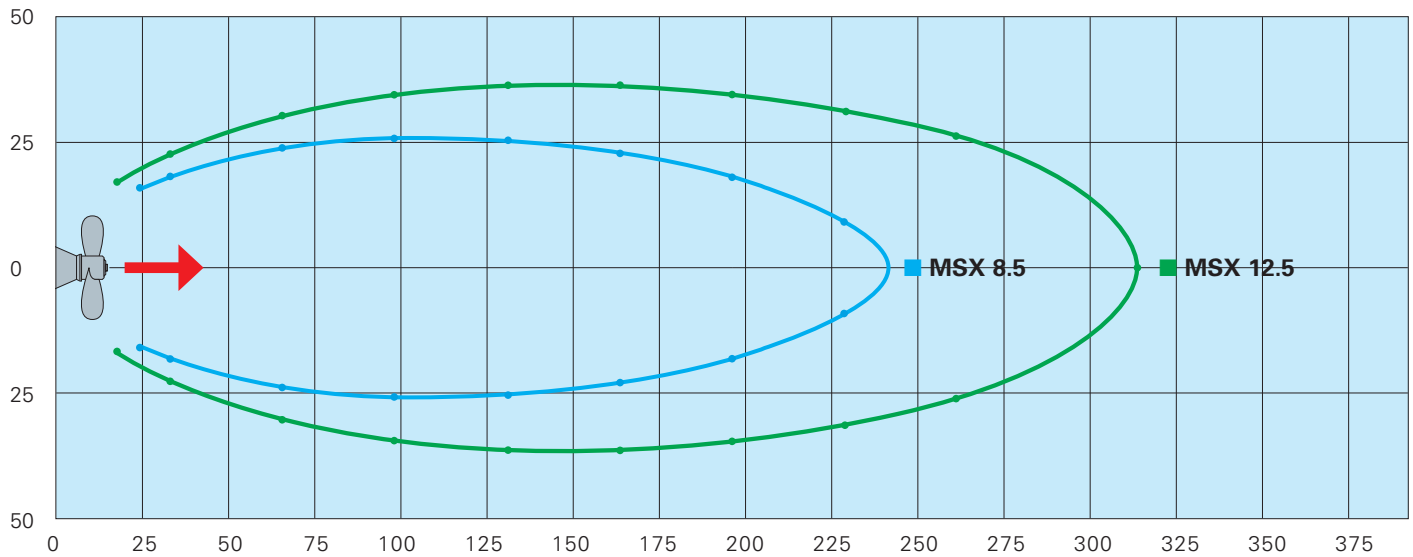

Flow range in ft with 0.1 m/s (values apply to water)

Your Dealer:

BAUER North America
 Office: Michigan City
 Tel. 1-800-922-8375
 sales@bauer-at.com
 www.bauer-at.com

A **BAUER Group** company

